

mott *corporation*

84 Spring Lane, Farmington, CT 06032-3159
860-747-6333 Fax 860-747-6739

WWW.MOTTCORP.COM

**Hiflow™ Nickel MICROFILTRATION MEDIA FOR GAS
AND LIQUID FILTRATION**

Sunil Jha and Kenneth L. Rubow

To be published in
Conference Proceedings

Volume 13

Advances in Filtration and Separation Technology
Advancing Filtration & Separation Solutions For The Millennium

April 6- April 9, 1999
Boston, Massachusetts

Hiflow™ Nickel MICROFILTRATION MEDIA FOR GAS AND LIQUID FILTRATION

Sunil Jha* and Kenneth L. Rubow
Mott Corporation
84 Spring Lane
Farmington, CT 06032

ABSTRACT

This paper describes the properties and cross flow filtration test results of Hiflow Nickel media developed for microfiltration. Polymeric, ceramic and titania/zirconia coated stainless steel media are currently available with filtration ratings as low as 0.05 μm and finer. The polymer membrane lack in strength, pressure and temperature capability and their disposal may be an environmental issue. The permeability of polymeric, ceramic and ceramic-coated stainless steel media is also limited. A high permeability metal media suitable for microfiltration has the advantages of high pressure and temperature capability, weldability, corrosion resistance and recyclability. The Hiflow Nickel media is available for cross flow and barrier filtration of liquids and gases.

INTRODUCTION

There is continued need for filtration media with fine porosity, high pore volume fraction, high temperature capability and high strength and corrosion resistance. While polymeric media are available with filtration ratings as low as 0.05 μm and finer (Scott, K., 1995), the polymer membranes lack strength, pressure and temperature capability. Disposal of contaminated polymeric media is often difficult and expensive, and may become an environmental issue. Fine pore size ceramic media or titania/zirconia coated stainless steel media are available; however, the permeability of such composite media is limited. Limited permeability increases the size and cost of filtration systems. Multilayer ceramic or ceramic composite media are brittle and prone to failure during handling or filter assembly, and can not be welded. Ceramic media can easily break during transportation and must be packaged and transported with special care. Ceramic media are sensitive to thermal and mechanical shock.

Metal media rated for fine particle filtration in the microfiltration range with high permeability will possess mechanical and thermal shock resistance, and provide the ability to build welded and corrosion resistant filtration systems. These filters can be cleaned-in-place by back pulsing, or by other methods for cleaning metal filters. Disposal of the metal filters at end-of-life will be

easier and more environmentally friendly, since metal is recyclable. Recyclability however will also depend on the nature of the contaminant.

This paper describes the properties of Hiflow Nickel media that is available in Mott's 0.2 and 0.1 μm filtration ratings, has high pore volume fraction, and therefore high fluid permeability. A newly developed proprietary processing technology is applied to manufacture this fine porosity and low density nickel media. The Hiflow Nickel media is welded to stainless steel or nickel hardware and has high strength and toughness for back pulsing.

PROPERTIES OF Hiflow™ Nickel MEDIA

The important filter media properties for successful commercial applications include the following:

1. Strength and microstructure
2. Permeability
3. Available geometry, i.e. whether sheet, tubular, cartridge and dimensions
4. Corrosion resistance
5. Joining and Sealing methods
6. Media cleanability
7. Filtration efficiency

Media Strength and Microstructure

Figure 1 shows a photomicrograph of 0.2 μm rated Hiflow Nickel media. The media is manufactured as 24" long porous tube, with outer diameters ranging from 0.375 to 1 in. and wall thickness ranging from 0.050 to 0.100 in. The media is made using a novel process, proprietary to Mott Corporation. The new process provides an attractive combination of fine porosity (sub-micrometer sized, interconnected flow pores) and high porosity fraction (40 to 65%), that has not been previously obtained in standard sintered porous media.

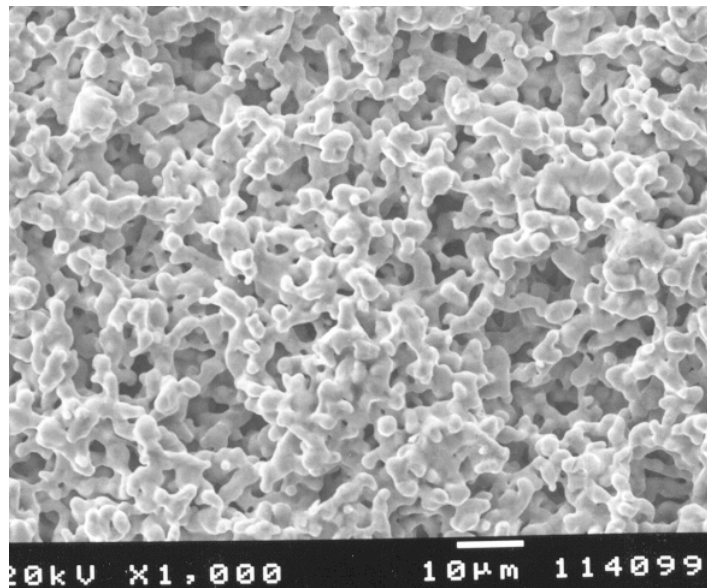

Figure 1: Photomicrograph of 0.2 μm HiFlow™ Nickel Media

Since the flow pores are tortuous in nature, even though the pore dimensions appear to be micrometer size, the tortuosity and the flow path length provides effective obstacle to the passage of sub-micrometer particles through the media. Filtration efficiency is a strong function

of the particle concentration, particle size distribution, agglomerate size or floc size in case of sub-micrometer size particles and the fluid flow rate. Therefore, the physical pore size of the media does not represent the filtration efficiency or rating of the media. As is apparent in the microstructure shown in Figure 1, the particles building the media are well sintered and provide intrinsically high media strength. Table 1 shows the typical dimension, porosity fraction and tensile strength of the Hiflow Nickel media. The strong media can be back-pulsed to dislodge particle cake formed during filtration, and recover the fluid flow. The high media strength provides high collapse (in excess of 1000 psi for 0.5 in. diameter tubes) and burst pressures of the media tubes. The high strength helps in the construction of robust filter modules, which can be operated at high pressures and temperatures approaching 500°F.

Table 1: Physical Properties of Hiflow Nickel Media

Mott Grade (μm)	Tube Inner Diameter (inches)	Wall Thickness (inches)	Porosity %	Tensile Strength (psi)
0.2	0.35	0.10	60	4000
0.1	0.34	0.09	40	12000

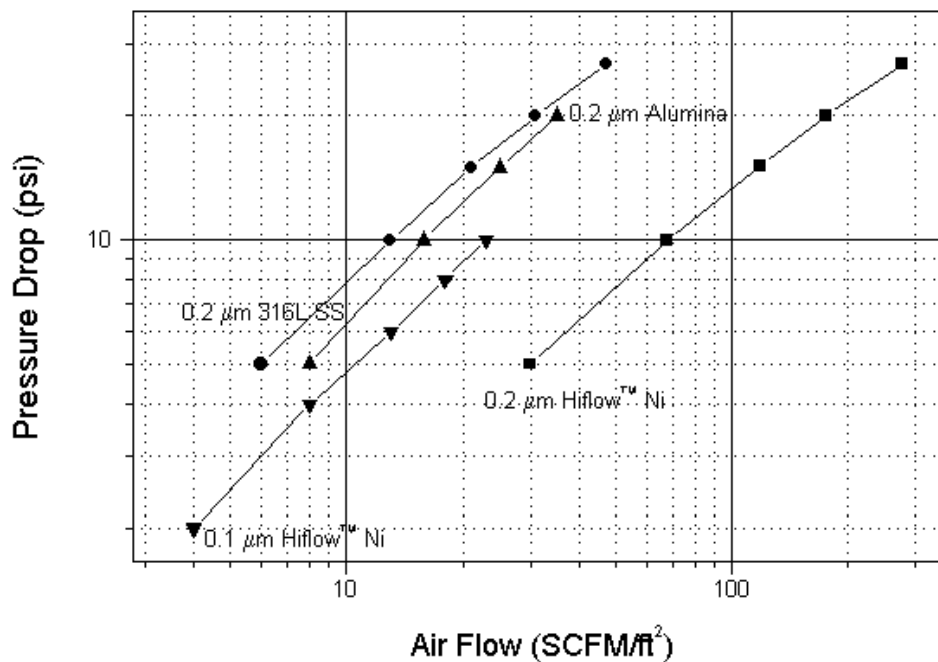

Figure 2: Air Permeability of HiFlow™ Nickel Media

Media Permeability

Figures 2 and 3 show the air and liquid permeability of the Hiflow Nickel media, respectively. For comparison, the permeability of 0.2 μm 316L Stainless Steel (SS) and 0.2 μm alumina ceramic media is also plotted in the same figures. The liquid permeability of 0.2 μm Hiflow Nickel media is similar to that of Mott 0.5 μm 316L SS filter elements. The air permeability of 0.2 μm Hiflow Nickel media is similar to that of Mott 1 μm 316L SS filter element. The air

permeability of 0.2 μm rated Hiflow Nickel media is four times larger than that of 0.2 μm rated alumina ceramic membrane, which is supported on coarser porous alumina structure. The data

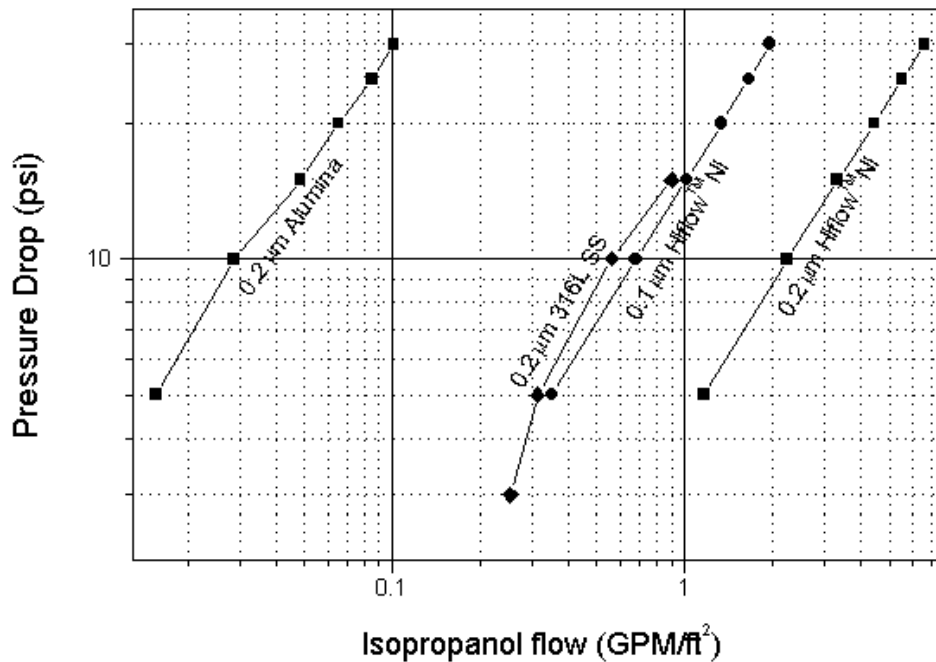

Figure 3: Isopropanol Permeability of HiFlow™ Nickel Media

shown in Figures 2 and 3 illustrate that the permeability of Hiflow Nickel media is significantly higher than the permeability of commercially available stainless steel filters and ceramic membranes.

Available Media Geometry

The Hiflow Nickel media is currently available as tubes, with outer diameters ranging from 0.38 to 1.0 in., and are made in 24 in. lengths. The media wall thickness may range from 0.060 to 0.100 in. The thicker wall provides strength and filtration efficiency. These are the basic building blocks that are welded to make longer lengths, as needed. The Hiflow Nickel media is welded to solid tubes or other hardware that can be attached to tube sheet and supports. In this manner, large filtration modules can be assembled.

Media Corrosion Resistance

The corrosion guidelines for Hiflow Nickel media is based upon the exposure of wrought Nickel 200 metal (UNS N02200). Figure 4 shows the galvanic series of various common metals and alloys, and it shows that the corrosion potential of Nickel in 5% NaCl solution is comparable to that of passivated stainless steels (Fontana, M.G., 1986). A porous material will have a higher corrosion rate than a corresponding solid material of the same chemistry due to its high exposed surface area. In the case of Nickel, in general, reducing conditions retard corrosion attack, whereas oxidizing conditions promote corrosion. Nickel porous materials can be used in handling bromine, halogen gases, and chlorinated solvents. Nickel is used widely in the food processing industry. Nickel is resistant to neutral and mild acidic solutions, but is readily attacked by oxidizing acids, such as nitric acid. Alkaline solutions and mild atmospheric conditions do not affect Nickel. Nickel has limited corrosion resistance in seawater and brackish water.

Joining and Sealing Methods

The Hiflow Nickel media can be welded by a variety of standard industrial welding techniques to stainless steel or Nickel hardware. This avoids the use of seals or o-rings and allows for the fabrication of completely welded filtration units.

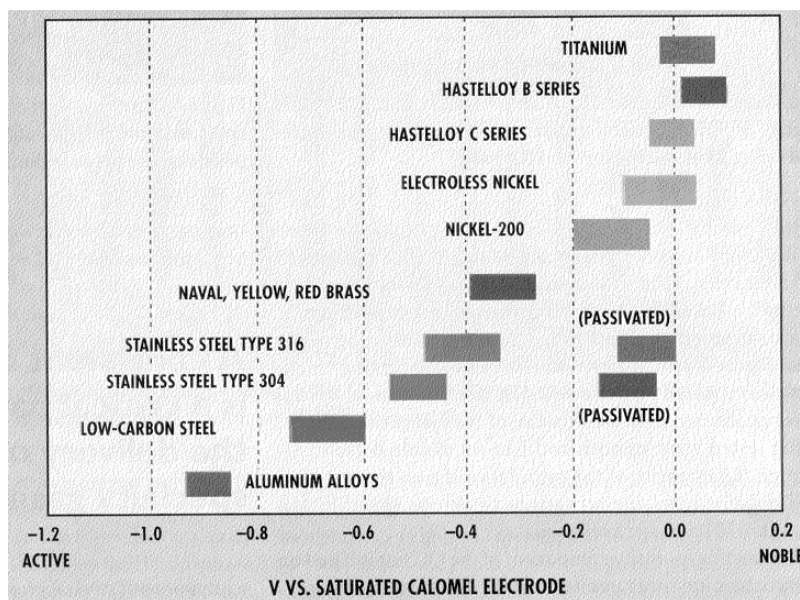

Figure 4: Galvanic Series of Metals and Alloys in 5% NaCl Solution

Media Cleaning

The Hiflow Nickel media can be cleaned *in-situ* by backpulsing, or backwashing the media with the permeate. The media can also be cleaned in caustic solution in ultrasonic bath, if required.

APPLICATION TESTS WITH HiFlow™ Nickel MEDIA

A series of liquid cross flow filtration tests were performed with Hiflow Nickel media of 0.1 and 0.2 μm rating. The results were compared with similar tests performed on 0.5 and 0.2 μm rated 316L SS media. Figure 5 shows a schematic diagram of the Mott LSX cross flow filter used. A single element Mott LSX cross flow filter was used to perform the application tests. In all application tests described here, the filtrate was returned to the feed tank. The cross flow tests showed that filtration performance was highly dependent on the nature and morphology of the particles, size and distribution, volume % of particles in the slurry, mainstream velocity and trans-membrane pressure. The particle size distribution in the slurry was measured using Horiba LA910 laser scattering particle size distribution analyzer. The particle size data described below are based on the number distribution of particle sizes in the test slurry. The filtrate turbidity was used as an indicator of the filtrate quality.

Test 1: Spent Platinum-on-Carbon Aqueous Slurry

Table 2 shows the particle size data in the slurry and filter geometry used for cross flow filtration of spent Platinum-on-Carbon slurry. Table 3 shows the optimal operating conditions for cross flow filtration of aqueous slurry of Platinum-on-Carbon spent catalyst. For comparison, cross flow tests were also carried out using 0.5 μm 316L SS media. Particle breakthrough was observed as filtrate turbidity ranged from 0.25 to 4.0 NTU (Nephelometric Turbidity Units). For reference, the turbidity of tap water ranges from 0.1 to 0.3 NTU. Trans-membrane pressure required for maintaining a 0.16 gpm/ft^2 filtrate flux ranged from 30 to 60 psi. The 0.5 μm 316L Mott Corporation

SS media was back-washed at 60 psi to recover the filtrate flow rate to 0.3 gpm/ft². However, the filtrate flow attenuated to the steady state of 0.16 gpm/ft² within 5 minutes. The benefit of 0.2 µm rated Hiflow Nickel media over the 316L SS media is primarily in higher filtrate flux rate, and better efficiency of backwash. Better backwash efficiency results from the high porosity of the media, where the pressure pulse is effective in removing the deposited cake layer.

Table 2: Particle Size and Filtration Data	
<u>Particle Size Data</u>	<u>Filter Test Data</u>
Mean particle size: 2.6 µm	Feed particle concentration = 2000 PPM
Std Dvn: 1.0 µm	Media: 0.2 µm Hiflow Nickel filter tubes
% Particles <1 µm: None detected	Filter dimensions: 0.5" O.D. x 0.35" I.D. x 24" Length
	Total test time: 16 hours

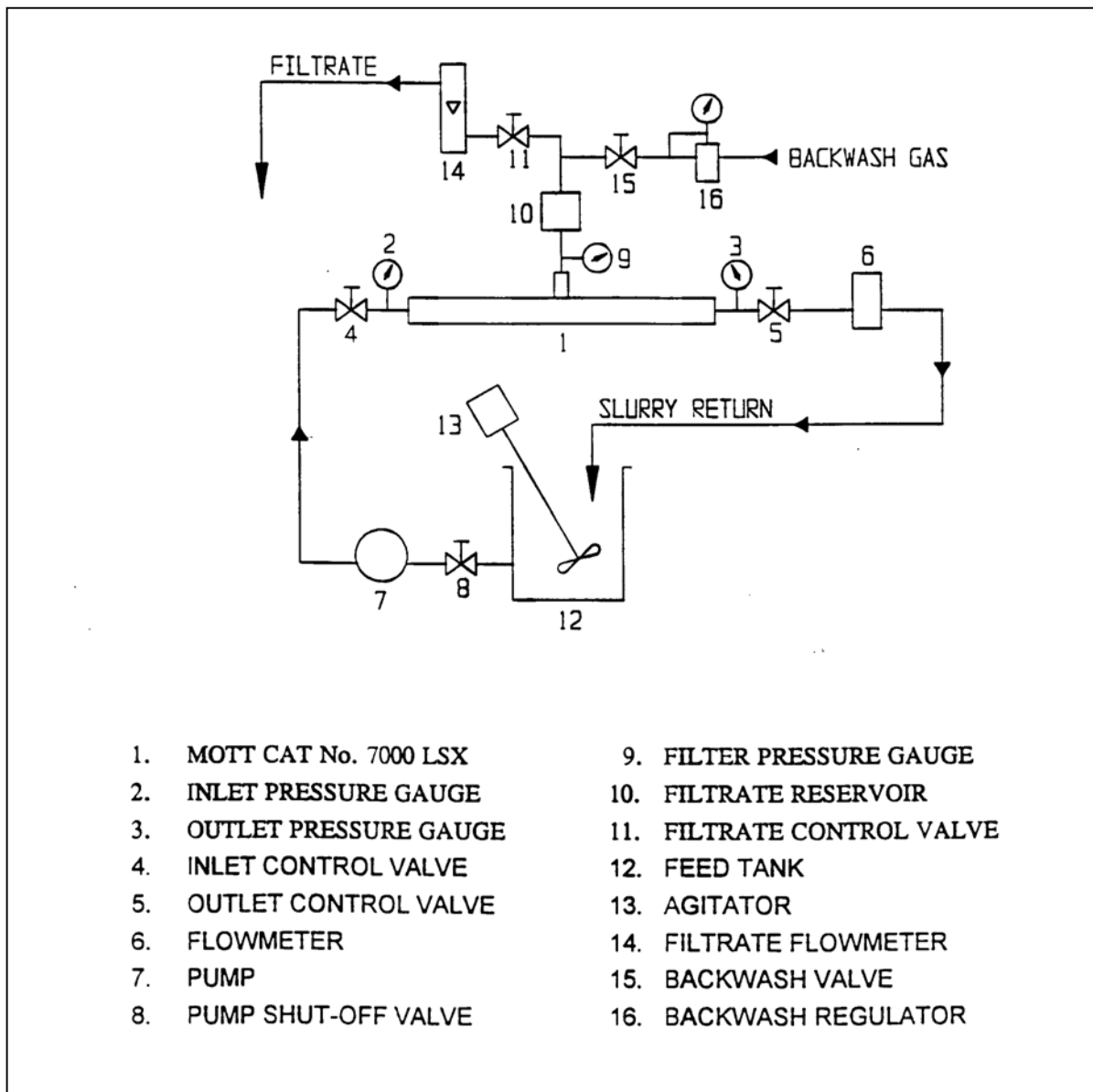

Figure 5: Schematic Diagram of Crossflow Filter

Table 3: Cross Flow Filtration Data for Platinum-on-Carbon Slurry.

<u>Cross Flow Parameters</u>	<u>Clean Flow</u>	<u>Slurry Flow</u>
Mainstream velocity	6 FPS (Feet per second)	10 FPS
Steady state filtrate flow rate	3.5 gpm/ft ²	0.1 gpm/ft ²
Trans membrane pressure drop	4.5 psi	21 psi
Filtrate quality		0.1 NTU
Backwash pressure		20 psi
Filtrate flow rate after backwash		0.3 gpm/ft ²
Time to attenuate to steady flow		30 minutes

Test 2: AC Fine Test Dust slurry in tap water

Table 4 shows the particle size and filter data for cross flow filtration of AC fine test dust slurry. Table 5 shows the conditions at which the cross flow filter was operated to obtain optimal operating conditions. After 72 hours of testing, the particle size distribution in the slurry was determined again. The % number of particles below 1 µm had increased, probably due to de-agglomeration or attrition, as follows:

Mean initial particle size: 1.17 μm
 Standard deviation: 0.62 μm
 %Particles below 1 μm : 76 %

With the reduction in particle size, and increase in the fraction of smaller particles, the flow properties of the 0.2 μm Hiflow Nickel cross flow filter changed. Table 6 shows the cross flow filtration parameters for ACFTD slurry after de-agglomeration or attrition. AC Fine test dust particles have higher density and therefore the particles tend to settle. At lower mainstream velocity range of 2 to 4 FPS (feet per second), the filtrate flux was less than 0.1 gpm/ft^2 . To improve filtrate flux, the mainstream velocity was increased to 6 FPS. This maintained the steady state filtrate flux rate at 0.1 gpm/ft^2 . Backwashing the media with 60 psi pulse recovered the flow to 0.3 gpm/ft^2 and the flow would settle at 0.1 gpm/ft^2 in 30 minutes.

Table 4: Particle Size And Filter Test Data for ACFTD Slurry

<u>Particle Size Data</u>		<u>Filter Test Data</u>
Mean particle size:	1.1 μm	Feed particle concentration = 1 wt. %
Std Dvn:	0.7 μm	Media: 0.2 μm Hiflow Nickel filter tubes
%Particles <1 μm :	66%	Filter dimensions: 0.5" O.D. x 0.35" I.D. x 24" Length
		Total test time: 72 hours

Table 5: Cross Flow Filtration Parameters for ACFTD Slurry

<u>Cross Flow Parameters</u>	<u>Clean Flow</u>	<u>Slurry Flow</u>
Mainstream velocity	6 FPS (Feet per second)	6 FPS
Steady state filtrate flow rate	3.5 gpm/ft^2	0.3 gpm/ft^2
Trans membrane pressure drop	4.5 psi	21 psi
Filtrate quality		0.1 NTU

Table 6: Cross Flow Filtration Data for ACFTD Slurry After 72 Hours

<u>Cross Flow Parameters</u>	<u>Slurry Flow</u>
Mainstream velocity	6 FPS
Steady state filtrate flow rate	0.1 gpm/ft^2
Trans membrane pressure drop	22 psi
Filtrate quality	0.1 NTU
Backwash pressure	60 psi
Recovered flow after backwash	0.3 gpm/ft^2
Time to attenuate to steady flow	1 Hour

Test 3: Titanium di-oxide slurry in tap water

Titanium di-oxide particles are produced in very high volumes, and have a myriad of applications in industrial and consumer products. It is widely used in paints, and often sold as concentrated slurry. Cross flow filtration of titanium di-oxide particles has been used to make slurries with concentrations ranging from 50 to 80% (Trendell et al., 1997). Wastewater recovery of titanium oxide particle containing waste is also of potential interest. Previous attempts for barrier filtration of titanium di-oxide particles at Mott's R&D laboratory were unsuccessful and the particles were found to readily coat and plug the filter media. Cross flow filtration of titanium di-oxide slurry was attempted with 0.1 μm Hiflow Nickel media. A surfactant was used to keep the slurry de-flocculated. The pH of the slurry was 6.8, and at this

pH, the particles have been found to remain well-dispersed (Marchant and Wakeman, 1997). Table 7 shows the relevant particle size and filter data for cross flow filtration of titanium dioxide slurry. Table 8 shows the optimum operating conditions for titanium di-oxide slurry filtration. There was no need to blow back the filter since the steady state flow was high and the filtrate turbidity was extremely low. The test was run for three days and various parameters were adjusted. In all cases, the cross flow filter operated at a steady flow rate with no indication of media fouling or loss in flux.

Subsequently, the slurry was concentrated by withdrawing the filtrate. Table 9 shows the results of concentration trials. It is clear that as the slurry concentration increases, more energy is required to maintain adequate mainstream velocity. In the concentration range tested, the filtrate quality was independent of the feed concentration. It is potentially possible to concentrate the slurry to higher levels by applying higher pumping capacity and higher trans-membrane pressure. Further, the behavior of titanium oxide slurries depends strongly on the pH and Zeta potential. The solution pH governs the viscosity and the floc size of the titanium oxide particles.

Table 7: Particle Size And Filter Data for Titanium di-Oxide Slurry Filtration	
<u>Particle Size Data</u>	<u>Filter Test Data</u>
Mean particle size: 0.5µm	Feed particle concentration = 1 wt.% in tap water
Std Dvn: 0.2 µm	Media: 0.2 µm Hiflow Nickel filter tubes
%Particles <0.5 µm: 77%	Filter dimensions: 0.5" O.D. x 0.35" I.D. x 24" Length
	Total test time: 16 hours

Table 8: Optimal Operating Parameters for Titanium di-Oxide Filtration		
<u>Cross Flow Parameters</u>	<u>Clean Flow</u>	<u>Slurry Flow</u>
Mainstream velocity	6 FPS	7 FPS
Steady state filtrate flow rate	1.4 gpm/ft ²	1 gpm/ft ²
Trans membrane pressure drop	7.5 psi	21 psi
Filtrate quality		0.05 NTU
Slurry pH		6.8

Table 9: Results Of Concentrating Titanium di-Oxide Slurry				
Concentration	Mainstream velocity (FPS)	Steady state filtrate flux (gpm/ft ²)	Trans membrane pressure (psi)	Filtrate turbidity (NTU)
1%	7	1	21	0.05
1.5%	6	0.8	12.5	0.18
2%	6	0.7	23	0.10
3%	6	0.6	27	0.05
6%	6	0.3	23	0.07

SUMMARY AND CONCLUSION

A high permeability, fine porosity Nickel metal media has been developed that has the essential advantages of a metal filter i.e., strength, corrosion resistance, weldability and recyclability. There are added advantages of high porosity, which will lead to efficient blowback and smaller filter module size for a given throughput requirement.

Having performed the application tests with catalyst slurry, AC fine test dust slurry and titanium di-oxide slurry, it appears that this media will be suitable for industrial scale cross flow filtration of various slurries, either for clarification or wastewater recovery. Finer pore sizes will provide higher media life with reduced particle embedding.

FUTURE WORK

Additional work will be performed to investigate the application of Hiflow Nickel media in the following areas:

1. Cross flow filtration relevant to food, beer and wine, bio-pharmaceutical and semiconductor industries.
2. Gas filtration for the biological/nuclear/chemical air contamination markets.
3. Micro-filtration in the waste recovery systems for paint, pigments and machine shops.

ACKNOWLEDGEMENT

The efforts and help of William Zukauskas, Louise Stange, Alex Amara and Joyce Carpenter in the conduct of various phases of the work reported here are greatly appreciated.

REFERENCES

- Scott, K., 1995, Handbook of Industrial Membranes, First Edition, Elsevier Advanced Technology, Oxford, UK.
- Fontana, M.G., 1987, Corrosion Engineering, Third Edition, McGraw-Hill.
- Trendell, Michael J., Drury, Kevin, Spruce, Stephen R., Davis, Martin R.B., Robson, Keith, United States Patent No. 5,622,628, Issued Apr. 22, 1997.
- Marchant, J.Q., Wakeman, R.J., "Crossflow Microfiltration of Concentrated Titania Suspension", IchemE, The 1997 Jubilee Research Event, Apr. 1997, Vol. 2, pp. 1061-1064.